

## Digital output module

DO

M1-22A

### 8 sinking outputs (+VS VDC)

- ▶ Open collector NPN transistor to the controller's voltage supply return
- ▶ High current: 500 mA per output / 3A per module
- ▶ Individual LED status indicator for each output
- ▶ Optically isolated

**Note:** This is the U module. It replaces the older P (for Model 5100) and M1-21A (for Model 5200) modules.

### General specifications

Outputs per module	8
Output type	Sinking (NPN open collector)
Connector	Removable
Connection type	Screw terminal
Terminal wire size	14 – 22 AWG
Test point	All connections
Status indicator	One LED per input
Module size	1 controller bay

Isolation rating	500 VDC
Operating temperature	
Horizontal installation <sup>1</sup>	0 - 50°C
Vertical installation <sup>1</sup>	0 - 45°C
Storage temperature	-25 – 85°C
Humidity	5 – 95% non-condensing
5100 equivalent part number	U

1. Refer to the applicable controller datasheet for proper mounting instructions.

### Performance specifications

Parameter	Value
Nominal voltage (VN)	VS
Max OFF voltage	Open collector
Max ON voltage @:	
50 mA	0.9 VDC
500 mA	1.4 VDC
Max channel current	500 mA
Max module current	3 ADC
Max controller current	
Model 5100	3 ADC
Model 5200	8 ADC
Max leak current/channel	200 µADC

1. In the OFF state, the outputs are pulled internally high to +5 VDC via a 1KΩ series resistor with an LED.

## Digital output module

DO

M1-22A

### Typical Application

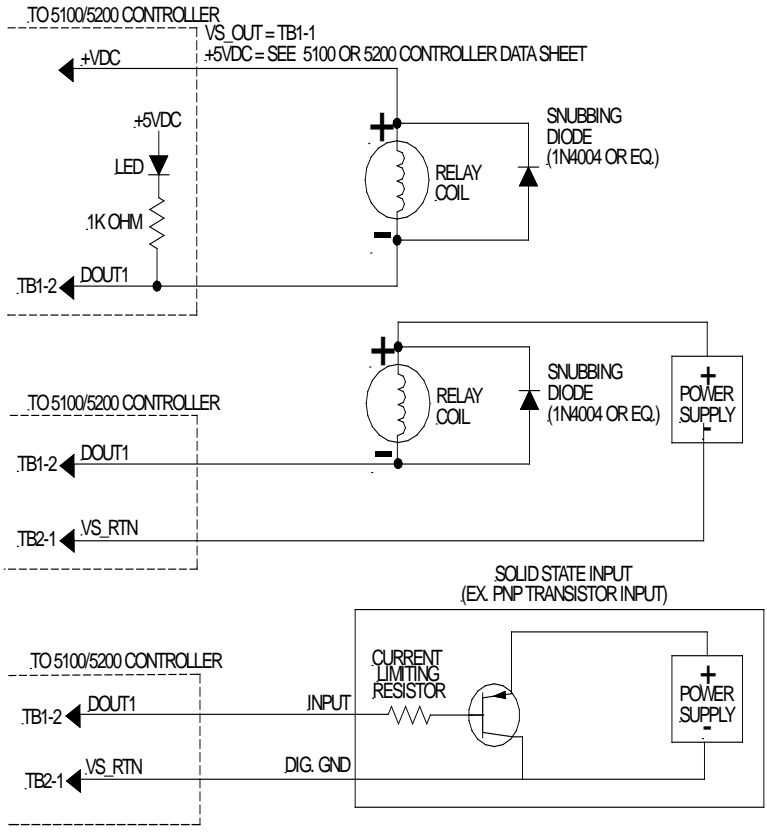

	5100	5200
Minimum hardware revision	0, A	0, A
Minimum firmware revision	N/A	N/A
Minimum operating system revision	4.04	5.06
Document number: 950-512202-0003		

### Connections

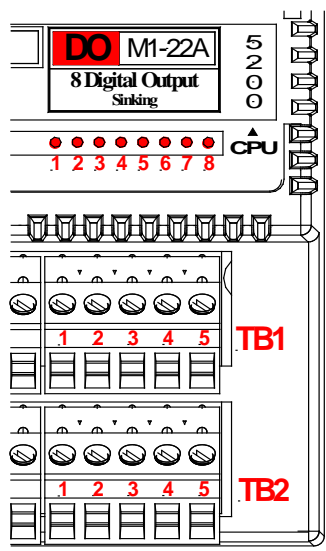

### I/O Terminations

TB1-1		VS_OUT
TB1-2	LED1	Dout #1
TB1-3	LED3	Dout #3
TB1-4	LED5	Dout #5
TB1-5	LED7	Dout #7
TB2-1		VS_RTN
TB2-2	LED2	Dout #2
TB2-3	LED4	Dout #4
TB2-4	LED6	Dout #6
TB2-5	LED8	Dout #8

### Notes

1. Observe proper current limiting with transistor loads.
2. Use high-speed diode or equivalent to limit inductive load kicks.
3. When a digital device is powered via an external power source, it may be necessary to tie the ground of this power source to the controller's voltage supply return (VS\_RTN).
4. For register and programming information, refer to the appropriate controller Applications Guide.
5. The information and illustrations contained herein are the property of Control Technology Corporation and are subject to change without notice. Data based on VS = 24VDC @ 25°C unless otherwise noted. For additional information and/or updates visit [www.ctc-control.com](http://www.ctc-control.com).