

Digital input module

DI

M1-11B

8 sinking inputs (+VS VDC)

- ▶ Wide input hysteresis voltage for solid switch points
- ▶ Individual channel status LEDs
- ▶ Optically isolated

General specifications

Inputs per module	8
Input type	VDC sinking
Connector	Removable
Connection type	Screw terminal
Terminal wire size	14 – 22 AWG
Test point	All connections
Status indicator	One LED per input
Module size	1 controller bay

Isolation rating	500 VDC
Operating temperature	
Horizontal installation ¹	0 - 50°C
Vertical installation ¹	0 - 45°C
Storage temperature	-25 – 85°C
Humidity	5 – 95% non-condensing
5100 equivalent part number	L

1. Refer to the applicable controller datasheet for proper mounting instructions.

Performance specifications

Parameter	Value
Input voltage (VS)	10 – 32 VDC
Max voltage	32 VDC
Nominal voltage (VN)	24 VDC
Turn ON threshold	0.46 * VS
Turn OFF threshold	0.12 * VS
Min hysteresis voltage	0.17 * VS
Min input current	2.6 mA @ 0 VDC
Input resistance to VS	10 K Ω \pm 10%
Min ON current	1.6 mA
Max OFF current	0.3 mA
Hardware filter	< 1 msec

Digital input module

DI	M1-11B
----	--------

Typical Application

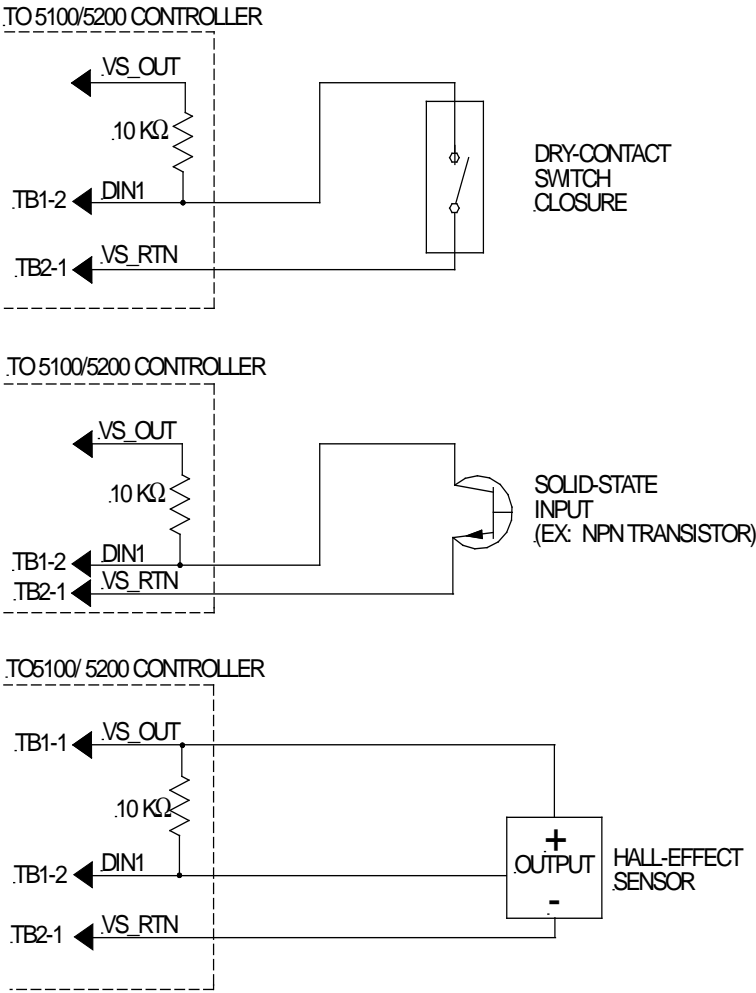

	5100	5200
Minimum hardware revision	0, A	0, A
Minimum firmware revision	N/A	N/A
Minimum operating system revision	4.04	5.06
Document number: 950-511106-0003		

Notes

- When a digital device is powered via an external power source, it may be necessary to tie the ground of this power source to the controller's voltage supply ground (VS_RTN).
- For register and programming information, refer to the appropriate controller Applications Guide.
- The information and illustrations contained herein are the property of Control Technology Corporation and are subject to change without notice. Data based on VS = 24VDC @ 25°C unless otherwise noted. For additional information and/or updates visit www.ctc-control.com.

Connections

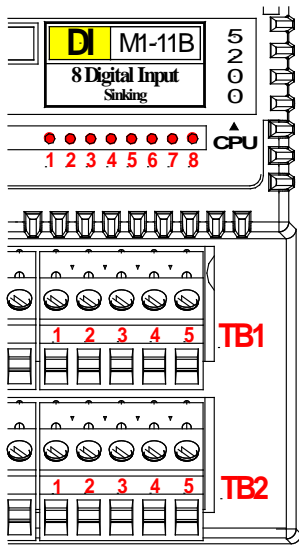

I/O Terminations

Terminal	Function	Controller Pin
TB1-1	VS_OUT	
TB1-2	LED1	Din #1
TB1-3	LED3	Din #3
TB1-4	LED5	Din #5
TB1-5	LED7	Din #7
TB2-1	VS_RTN	
TB2-2	LED2	Din #2
TB2-3	LED4	Din #4
TB2-4	LED6	Din #6
TB2-5	LED8	Din #8